



硬质合金柱钉

CARBIDE HPGR STUDS



关于我们 About Us

株洲贝特是一家综合性硬质合金制造商，公司始终秉承“工匠”精神，专注于硬质合金的研发生产，为客户提供耐磨、切割、冲压问题优化解决方案。

硬质合金柱钉和边块是我们优势产品系列之一。我们致力于为我们的合作伙伴提供创新优化的方案、技术和服务，帮助我们的合作伙伴节省成本和提高生产效率。

ZZbetter is an integrated tungsten carbide manufacturer and carbide solution provider. Tungsten carbide HPGR Studs and Edge blocks are two of our main products. We provide innovative solutions, technology, and service to our customers and partners, and have been helping our customers to save costs and improve productivity.

What can we do for our partners?

1. Innovative solutions for HPGR studs and edge block in Iron Ore, Diamond, Molybdenum, Gold, Copper and cement industry.
2. Help customers to grow and expand business operations.
3. Complete after-sales service.

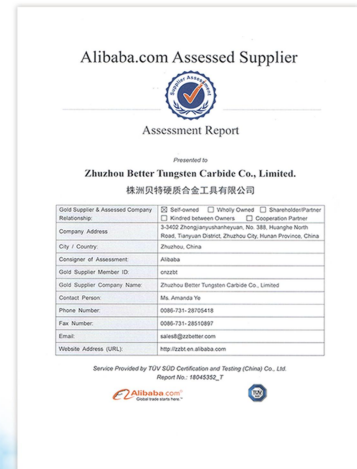
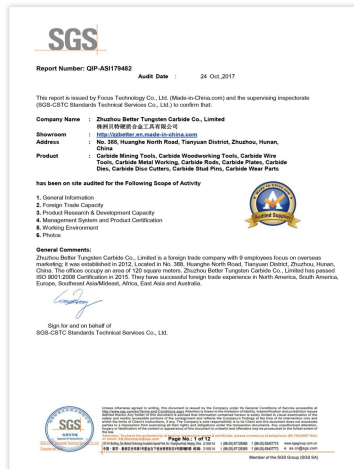
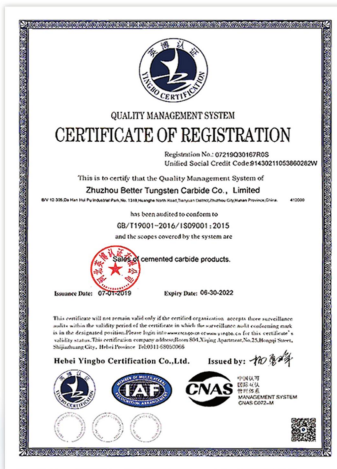

辊压机柱钉

Carbide HPGR Studs

辊压机是目前已知最高效的破碎设备之一，柱钉是辊压机的核心配件。株洲贝特硬质合金工具有限公司生产的硬质合金柱钉，耐磨性好，抗压强度高，可满足不同工况的使用需求，比如铁矿，铝矿，金矿，铜矿，水泥工业等。

The roller press is one of the most efficient crushing equipment at present, and the roller press's core accessory is the tungsten carbide studs. With high quality raw material and advanced equipment, ZZBetter provides the excellent wear and shock resistance to meet the apply demands in different tough working situations, such as Iron Ore, Diamond Ore, Molybdenum Ore, Gold Ore, Copper Ore, etc.

我们的优势 Our Advantages

耐磨性好，抗压强度高

Excellent wear resistance and shock resisting toughness.

优质的原生料，确保优越的物理性能

High quality raw material to keep superior physical performance.

尺寸齐全，接受定制

Both standard sizes and customized sizes are available.



牌号 Grades

牌号 ZZBT Grade	密度 Density (g/cm ³)	硬度 Hardness (HRA)	抗弯强度 T.R.S (MPa)	推荐应用 Recommended Application
BT30	14.36-14.48	≥87	≥2950	For grinding soft and middle hard stones or mines 适用于软中硬岩石或矿石
BT35	14.12-14.30	≥86.8	≥3050	For grinding soft and middle hard stones or mines 适用于软中硬岩石或矿石
BT40	13.90-14.18	≥86.5	≥3150	For grinding hard stones or mines 适用于坚硬岩或矿石
BT45	13.65-13.88	≥86.5	≥3350	For grinding hard stones or mine 适用于坚硬岩或矿石
BT50	13.30-13.50	≥86.5	≥3250	For grinding hard stones or mines 适用于极硬岩或矿石

辊压机柱钉 Carbide HPGR Studs

型号及尺寸 Types and Sizes

型号Type	ØD	H	R	C
SPF1045	10	45	2.5	1.0
SPF1625	16	25	2.5	1.0
SPF1630	16	30	2.5	1.0
SPF1635	16	35	2.5	1.0
SPF1640	16	40	2.5	1.0
SPF1645	16	45	2.5	1.0
SPF2035	20	35	2.5	1.5
SPF2040	20	40	2.5	1.5
SPF2045	20	45	2.5	1.5
SPF2050	20	50	2.5	1.5

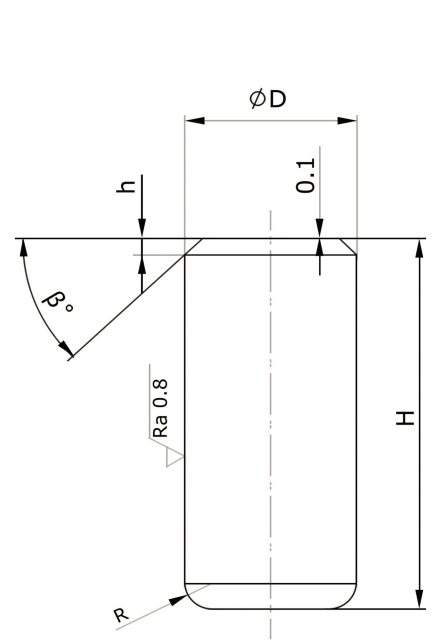

型号Type	ØD	H	R	Chamfer (E×R)
SPP2225	22	25	3	1.0×45°
SPP2230	22	30	3	1.0×45°
SPP2235	22	35	3	1.0×45°
SPP2240	22	40	3	1.0×45°
SPP2245	22	45	3	1.0×45°

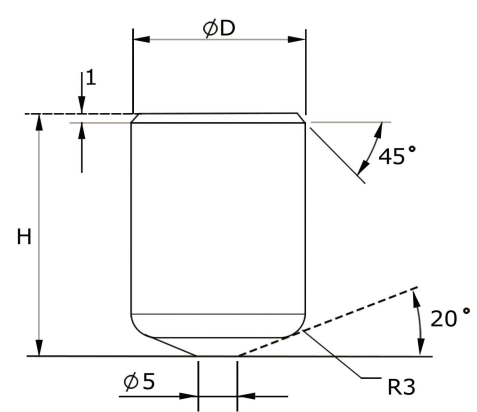

型号Type	ØD	H	SR	R
SPR1630	16	30	8	R1.5
SPR1635	16	35	8	R1.5
SPR1640	16	40	8	R1.5
SPR1645	16	45	8	R1.5
SPR2035	20	35	10	R2.0
SPR2040	20	40	10	R2.0
SPR2045	20	45	10	R2.0
SPR2050	20	50	10	R2.0

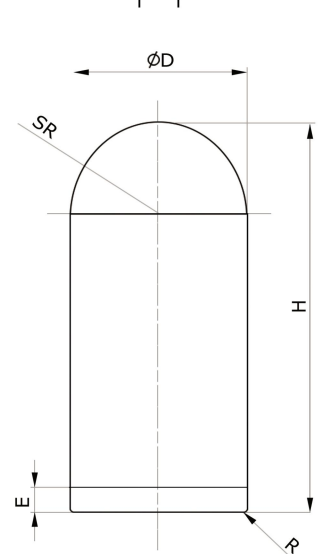

可以来样来图定制 We can produce according to your sample or drawing

辊压机边块

Carbide HPGR Edge Block

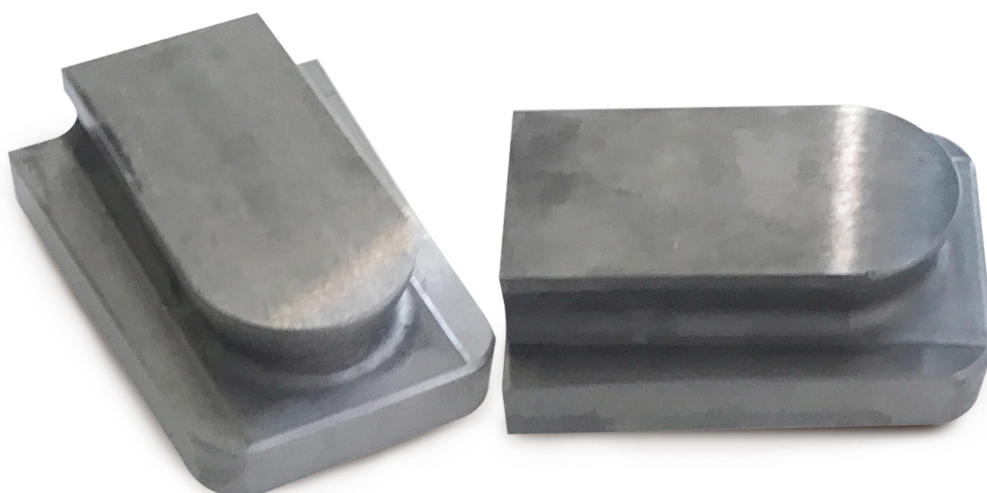

型号及尺寸 Types and Sizes

型号Type	L	W	T	R
EB627-1	62.70	48.60	23.60	8
EB627-2	62.70	48.80	23.80	10
EB628	62.80	47.00	23.80	10
EB630	63.00	49.20	23.80	10
EB632	63.20	49.80	23.90	8
EB633	63.30	50.00	24.00	10

mm

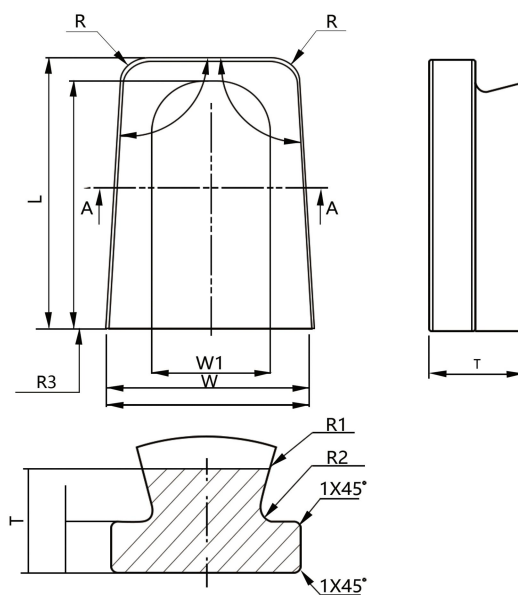

可以来样来图定制 We can produce according to your sample or drawing

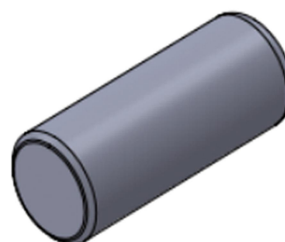
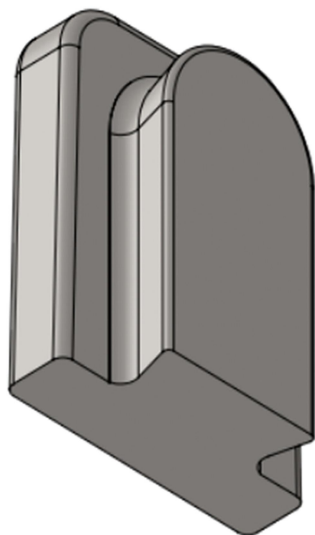



株洲贝特硬质合金工具有限公司

ZHUZHOU BETTER TUNGSTEN CARBIDE CO., LTD

国内销售部 Domestic Sales Department

邮箱: sales@zzbetter.com

电话: 0731-28705418

手机: 18173362238

网址: www.zzbetter.com

地址: 湖南株洲黄河北路大汉惠普信息产业园

国际销售部 International Sales Department

Mail: sales8@zzbetter.com

Tel: 0086 731 28705418

Mobile/Whatsapp: 0086 18173392980

Web: www.zzbetter.com

Add: Huanghe North Road, Tianyuan District,
Zhuzhou City, Hunan Province, China 412000

